

SELECTION CRITERIA

- Marine water use
 - Pilot operated
 - Actuation by pressure
 - 150 PSI water pressure rating
 - R-410A service
- Flanged end connections
 - 2-Way configuration
 - 6" & 8" sizes
 - 225 PSI proof pressure
 - Patented 650 PSI rated actuator designed to meet UL207

CONSTRUCTION DETAILS

- Bronze & Monel internals
 - Buna-N diaphragms & seals
- Bronze body per ASTM B62
 - ANSI B16.24 150# flanges
 - MIL-PRF-20042 flanges available

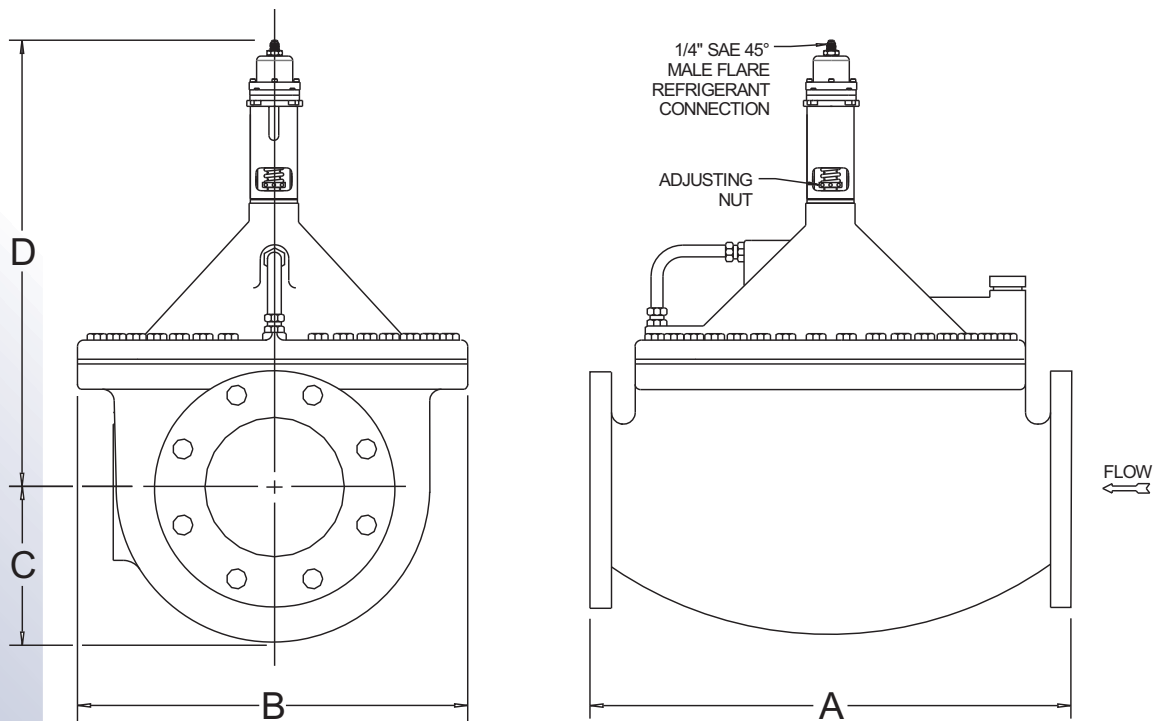

VALVE SIZING CHART

| VALVE PART NUMBER | PIPE SIZE | C _v | DIMENSIONS | | | | APPROX. SHIP WT. |
|-------------------|-----------|----------------|------------|---------|----------|-----------|------------------|
| | | | A | B | C | D | |
| YM65-3145C-2W | 6" | SEE TABLE 1 | 20" | 15-1/2" | 6-13/16" | 18-25/32" | 340# |
| YM65-3170C-2W | 8" | SEE TABLE 1 | 25-1/2" | 19-7/8" | 10-1/8" | 25-7/8" | 680# |

ORDERING INFORMATION

- Use the valve sizing chart on the preceding page tables and charts below to determine the complete part number.

BASIC PART NO.: YM65-3 C- -2W-

VALVE SIZING CHART _____
FLANGE* _____
TABLE I _____

- * "MF" for ANSI flange
- "NF1" for MIL-PRF-20042 150# Class
- "NF2" for MIL-PRF-20042 250# Class

PRESSURE RANGE ADJUSTMENT

- The refrigerant pressure at which the valve begins to open can be adjusted from 150 to 330 PSI. A 30 PSI increase of pressure is required to open the valve fully.

TRIM SELECTION

- TABLE 1 shows the Cv for available trim for each size valve. If no trim is specified, TA trim is provided. Minimum required differential pressures are also provided.

| VALVE PART NUMBER | TRIM DESIGNATOR | PIPE SIZE | C _v | MIN. Δ P |
|---------------------|-----------------|-----------|----------------|----------|
| YM65-3145C-MF-2W-TA | TA | 6" | 290 | 4 PSI |
| YM65-3145C-MF-2W-TB | TB | 6" | 180 | 4 PSI |
| YM65-3145C-MF-2W-TC | TC | 6" | 110 | 4 PSI |
| YM65-3145C-MF-2W-T1 | T1 | 6" | 245 | 4 PSI |
| YM65-3170C-MF-2W-TA | TA | 8" | 720 | 5 PSI |

VALVE FLOW DATA

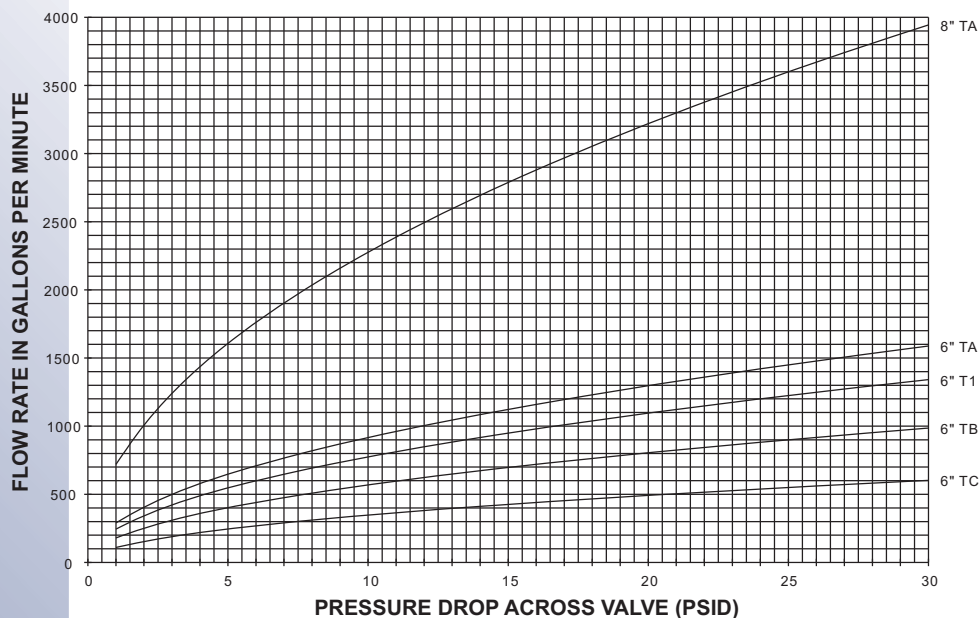

INSTALLATION INSTRUCTIONS

PAGE 3 OF 3

- 1) All valves should be mounted vertically on a horizontal water line. Valve can be installed upstream or downstream of the condenser.
- 2) Connect the incoming water line to the valve inlet. Direction of water flow (see drawing) is indicated by the arrow cast on the side of the valve body. Connect downstream water line to valve outlet.
- 3) Connect 1/4" male flare fitting on valve actuator to refrigerant head pressure connection on condenser. Use 1/4" copper refrigerant tubing, capillary tubing or other suitable tubing with 1/4" flare nut connections. Maximum tightening torque on flare nut is 15 ft-lbs.

2-WAY HEAD PRESSURE REGULATOR TYPICAL APPLICATION

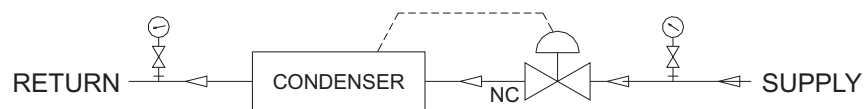

OPERATION INSTRUCTIONS

- 1) Start incoming water flow and the system water will flow through the internal passages into the chambers above the diaphragm. The force exerted by the upper diaphragm, due to the larger effective area, will overcome that acting against the valve seat and the valve will close.

"feedback" action of the modulating spring causes the main valve to hold a position proportional to the refrigerant pressure, and results in a very stable control valve allowing only the flow necessary for an efficient operating system.
- 2) To open the valve, sufficient actuating head pressure is required to overcome the tension on the power spring. The YM65 model is suitable for R-410a refrigerant pressures and is adjustable from 150-330 PSI. The valve controls the flow rate of water in response to changes in signal pressure (refrigerant pressure) to its pilot. The valve opens on increasing refrigerant pressure and closes on decreasing pressure. The refrigerant pressure acting upon the actuator exerts a force opposed by the power spring and modulating spring. Increasing refrigerant pressure overcomes the spring forces, and opens the pilot valve assembly. As the flow past the pilot valve exceeds the flow past the metering orifice or restrictor, the valve begins to open, compressing the modulating spring. As the modulating spring is compressed, its increased force reduces the pilot valve opening until the flow from the cover equals the flow into the cover. The main valve is now held at a fixed position that is determined by the refrigerant pressure. Decreasing refrigerant pressure results in the pilot valve lift decreasing, causing the valve to begin to close until the modulating spring force has decreased to match the change in refrigerant pressure actuator force. The
- 3) To increase the actuating refrigerant head pressure, insert a pin or hex key into the adjustment nut and turn counter-clockwise. To lower actuating refrigerant head pressure, turn adjustment nut clockwise.
- 4) The metering orifice or restrictor stem (on some models) controls water flow to the pilot and diaphragm and has been calibrated to give the proper flow throughout all pressure ranges normally encountered in such systems. If your valve is equipped with a restrictor assembly and not a metering orifice, occasional flushing and adjustment may be required if clogging occurs. To clean, remove restrictor cap and rotate the restrictor stem fully counter clockwise (with water flowing through the valve). This will flush out any particulate matter in the restrictor assembly. Then, fully rotate the stem until it contacts the restrictor seat. Next, rotate the stem 1/2 turn counter-clockwise. This should provide optimum results in most systems. If your system requires a different setting, adjust no more than 1/10 turn increments. If restrictor is not open enough, the valve will not close. If the restrictor is open too much, the valve will not open.

MAINTENANCE INSTRUCTIONS

Water to the valve must be clean and free of foreign particles. If the water supply is dirty, a strainer should be installed upstream of the valve and cleaned as often as is necessary. Foreign particles, if carried through the pilot passages, may tend to obstruct the metering orifice or restrictor and prevent the valve from closing. External tubing and internal passages,

including the metering orifice or restrictor should be cleaned periodically.

It is recommended that the valve be disassembled and inspected for wear or corrosion at 12 to 18 month intervals, depending on service conditions. Complete rebuild kits are available from Metrex Valve.