

SELECTION CRITERIA

- Fresh water use
 - Pilot operated
 - Actuation by temperature
 - Open on temperature increase
 - 150 & 75 PSI water pressure rating
- Flanged end connections
 - 2-Way configuration
 - 4", 6", & 8" sizes
 - 225, 200, & 114 PSI proof pressure

CONSTRUCTION DETAILS

- Brass & Stainless Steel internals
 - Buna-N diaphragms & seals
- Cast Iron body & bonnet
 - Flanges per ANSI B16.1 125#

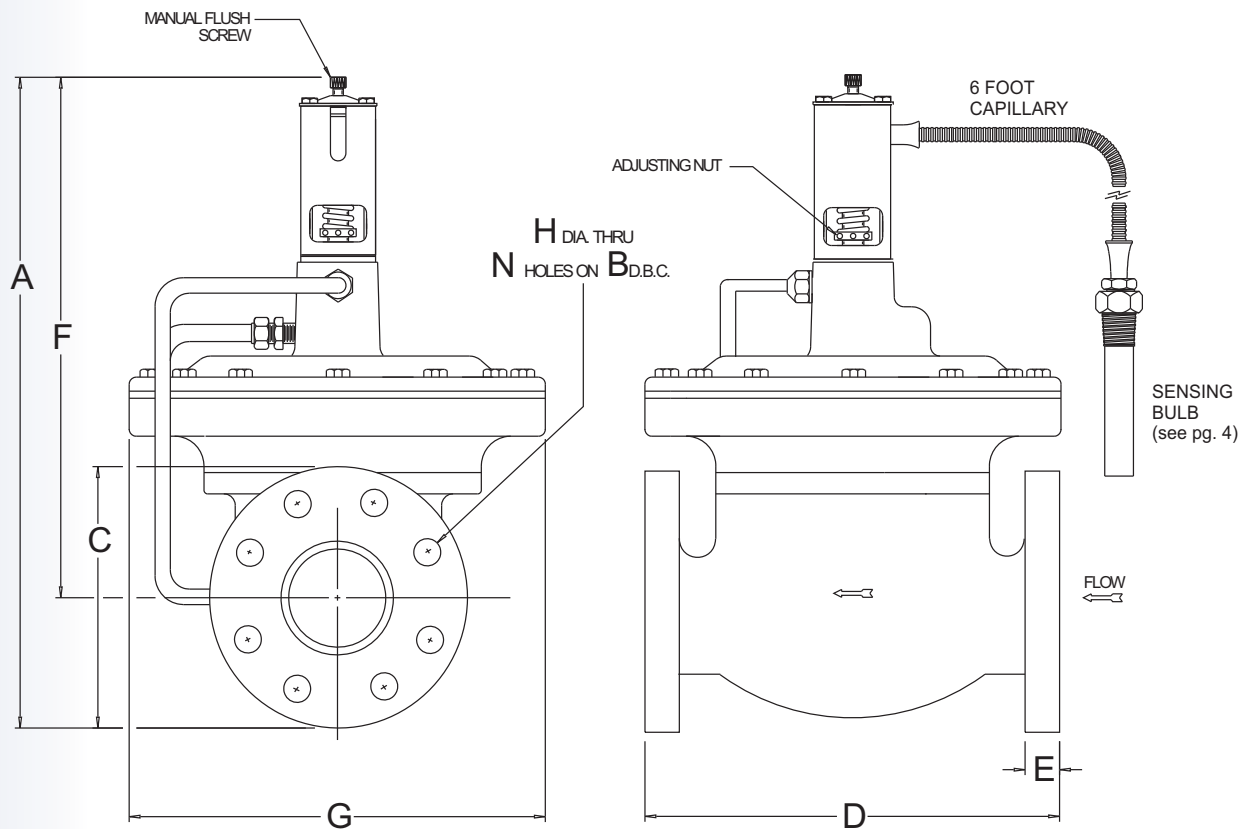

Reference Metrex drawing CR-3000-2W

VALVE SIZING CHART

VALVE PART NUMBER	PIPE SIZE	C _v	DIMENSIONS						FLANGE DATA			APPROX. SHIP WT.
			A	G	C	D	E	F	B	H	N	
CRT-3130-FL-2W	4"	SEE TABLE 1	20-3/16"	12-13/16"	9"	12-7/8"	1"	15-11/16"	7-1/2"	3/4"	8	155#
CRT-3150-FL-2W	6"	SEE TABLE 1	28-5/16"	19-7/8"	11"	20"	1"	18-13/16"	9-1/2"	7/8"	8	400#
CRT-3170-FL-2W	8"	SEE TABLE 1	28-1/16"	19-7/8"	13-1/2"	25-1/2"	1.12"	19"	11-3/4"	7/8"	8	600#

ORDERING INFORMATION

- Use the valve sizing chart on the preceding page, tables and charts to determine the complete part number.

BASIC

PART NO.: CRT-3 -FL-2W- -50M-XXX-X

VALVE SIZING CHART
TABLE I

ACTUATOR PART NUMBER (Pg. 4)

TEMPERATURE RANGES

Range Designator	Crack Open Temperature Adjustment Range	Change to Full Open Across the Range*
L low	5 to 105 F (-15 to 40 C)	35 to 12 F (19 to 7 C)
X cross ambient	60 to 140 F (15 to 60 C)	25 to 12 F (14 to 7C)
S standard	90 to 140 F (30 to 60 C)	20 to 12 F (11 to 7 C)
H high	100 to 170 F (40 to 80 C)	25 to 12 F (14 to 7C)
V very high	160 to 230 F (70 to 110 C)	40 to 21 F (22 to 12 C)

* The temperature change necessary to bring the valve from crack to full open decreases exponentially from the low end of the Crack Open Temperature to the high end of the Crack Open Temperature in each range. Example: a valve with a S (standard) range actuator set to open at 95°F will require an approximate rise in temperature of 20°F to go full open. The same valve set to open at 135°F will require an approximate rise in temperature of 12°F to go full open.

TRIM SELECTION

- TABLE 1 shows Cv for available trim for each size valve. If no trim is specified, TA trim is provided. The minimum differential pressure available for proper valve operation is listed in Table I. Maximum suggested pressure drop is listed in Table I.

VALVE PART NUMBER	TRIM DESIGNATOR	PIPE SIZE	C _v	DESIGN PRESS.	PROOF PRESS.	MIN. Δ P	MAX. Δ P
CRT-3130-FL-2W-TA	TA	4"	150	150	225	4	25
CRT-3130-FL-2W-TB	TB	4"	105	150	225	4	25
CRT-3130-FL-2W-TC	TC	4"	74	150	225	4	25
CRT-3150-FL-2W-TA	TA	6"	360	150	200	3.5	25
CRT-3150-FL-2W-TB	TB	6"	220	150	200	3.5	35
CRT-3170-FL-2W-TA	TA	8"	636	75	114	5	25

FLOW DATA

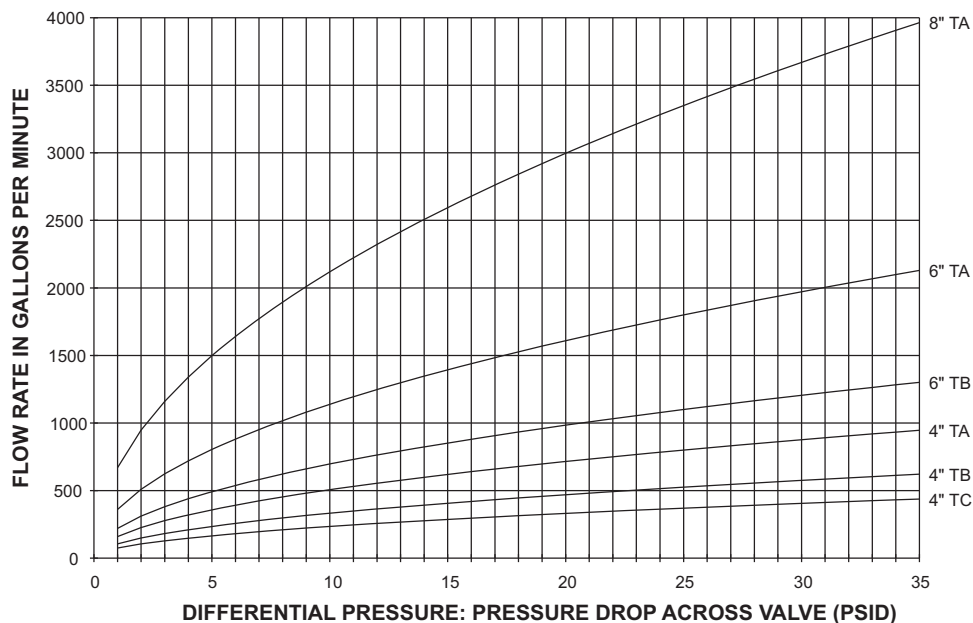

INSTALLATION INSTRUCTIONS

- 1) All valves should be mounted vertically on a horizontal water line.
- 2) Connect the incoming water line to the valve inlet. Direction of water flow (see drawing) is indicated by the arrow cast on the side of the valve body.
- 3) Insert / Install sensing bulb in desired location.

Important: The pilot drain line on the 2-way valve is factory plumbed to downstream side of the valve as shown in diagram. A minimum (see Table I) pressure drop across the pilot is required for condenser port to go full open. If available system pressure drop is less than this, disconnect the pilot drain line from the valve body and cap port in the side of the body, and connect drain line (3/8" minimum) from the pilot valve drain line fitting in the cover and run with minimum restriction to either:

- A) Atmospheric pressure such as a sump or reservoir which make full inlet pressure available across pilot valve.
- B) A connection downstream of the condenser. This increases the available drop to operate the valve by the amount of the pressure drop of the condenser.
- C) The suction side of pump if applicable.

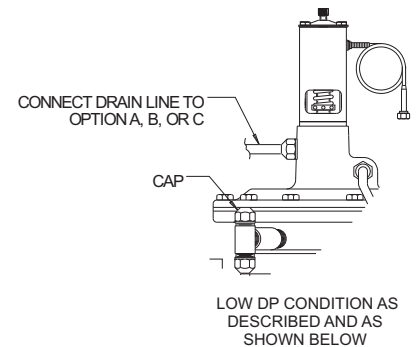
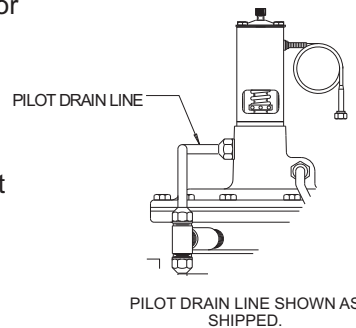

2-WAY TYPICAL INSTALLATION

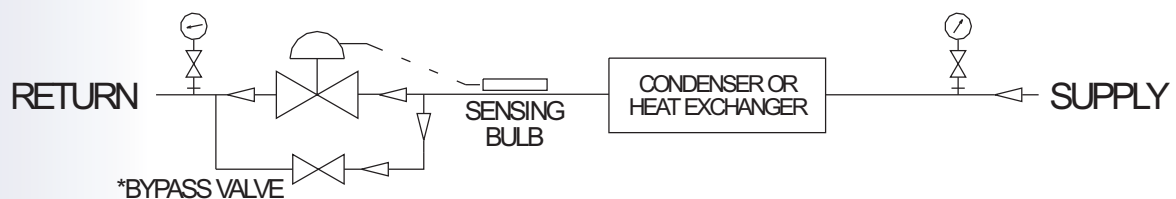

The Bypass allows a continuous low flow of water (usually 10% of maximum flow) through the heat exchanger to transport heat to the sensing bulb. Valves with internal bypass are available.

TO DETERMINE ACTUATOR PART NUMBER

1. Select the desired Bulb style for the appropriate valve series.
2. Select the Applicable Valve size.
3. Select the Temperature Range to reference the part number.

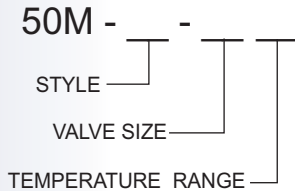

Example: For an application to control at 110°F, you could select our CR Series valve and specify a 50M-261S thermostatic actuator (see Model 261 on right).

MODEL 261 • 3/4" NPT INSERTION TYPE • "A"=3/4"			
VALVE SIZE	TEMPERATURE RANGE (°F)	L (in)	PART NUMBER
ALL	5-105 or 60-140	6.00	50M-261L or 261X
	90-140	2.25	50M-261S
	100-170 or 160-230	2.25	50M-261H or 261V

MODEL 318 • 1/2" NPT INSERTION TYPE • "A"=9/16"			
VALVE SIZE	TEMPERATURE RANGE (°F)	L (in)	PART NUMBER
ALL	5-105 or 60-140	11.00	50M-318L or 318X
	90-140	4.00	50M-318S
	100-170 or 160-230	4.00	50M-318H or 318V

MODEL 339 • PLAIN TUBE STRAP-ON TYPE • "A"=3/4"			
VALVE SIZE	TEMPERATURE RANGE (°F)	L (in)	PART NUMBER
ALL	5-105 or 60-140	6.00	50M-339L or 339X
	90-140	2.25	50M-339S
	100-170 or 160-230	2.25	50M-339H or 339V

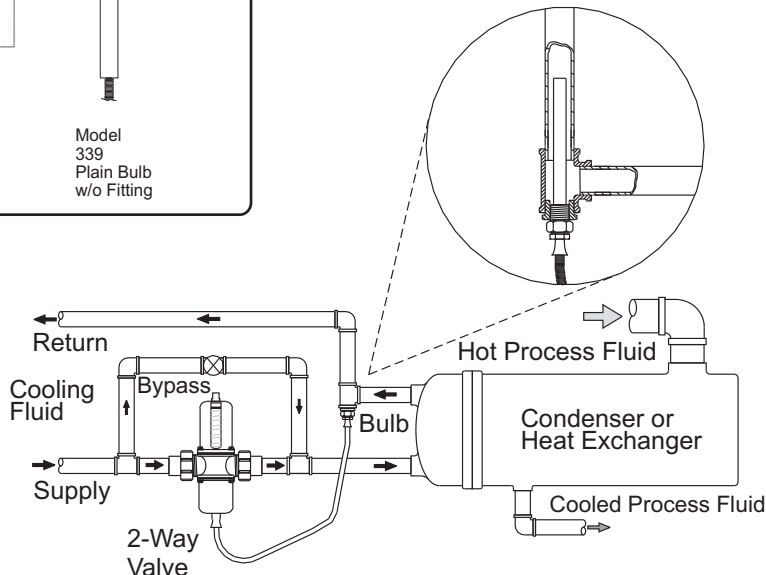
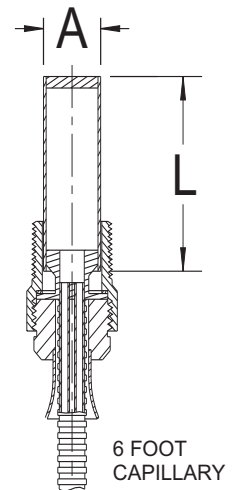
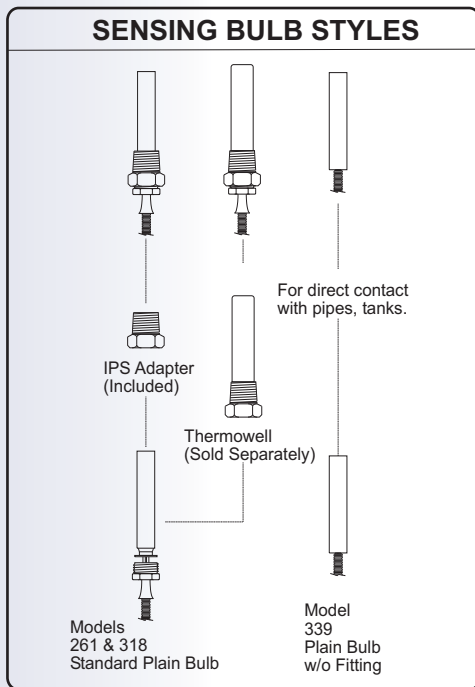

OPERATION INSTRUCTIONS

PAGE 5 OF 5

- 1) Start incoming water flow and the system water will flow through the external tubing into the chambers above the diaphragm. The force exerted by the upper diaphragm, due to the larger effective area, will overcome that acting against the valve seat and the valve will close.
- 2) To flush the valve through the outlet, independent of valve setting, insert an allen wrench into the manual flush screw and turn clockwise until the screw bottoms. After flushing, reverse this procedure for automatic operation. Caution: If the screw is not unscrewed or backed off sufficiently to clear the top plate on the bellows housing after flushing, the valve will not close.
- 3) To open the valve, sufficient temperature of the sensing bulb is required to overcome the tension on the power spring. The valve controls the flow rate of water in response to changes in temperature of the sensing bulb. The valve opens on increasing temperature and closes on decreasing temperature. The gas charge in the thermostatic actuator acting upon the bellows exerts a force opposed by the power spring and modulating spring. Increasing temperature overcomes the spring forces, and opens the pilot valve assembly. As the flow past the pilot valve exceeds the flow past the metering orifice or restrictor, the valve begins to open, compressing the modulating spring. As the modulating spring is compressed, its increased force reduces the pilot valve opening until the flow from the cover equals the flow into the cover. The main valve is now held at a fixed position that is determined by the temperature. Decreasing temperature results in the pilot valve lift decreasing, causing the valve to begin to close until the modulating spring force has decreased to match the change in gas pressure bellows force. The "feedback" action of the modulating spring causes the main valve to hold a position proportional to the temperature setting, and results in a very stable control valve allowing only the flow necessary for an efficient operating system.
- 4) To increase the temperature setting, insert a pin or hex key into the adjustment nut and turn counter-clockwise. To lower the temperature setting, turn adjustment nut clockwise.
- 5) The metering orifice controls water flow to the pilot and upper diaphragm, and has been calibrated to give the proper flow throughout all pressure ranges normally encountered in such systems. Other than temperature setting, there are no external adjustments required for automatic operation of the valve.

MAINTENANCE INSTRUCTIONS

Water to the valve must be clean and free of foreign particles. If the water supply is dirty, a strainer should be installed upstream of the valve and cleaned as often as is necessary. Foreign particles, if carried through the pilot passages, may tend to obstruct the metering orifice or restrictor and prevent the valve from closing. External tubing

including the metering orifice or restrictor should be cleaned periodically.

It is recommended that the valve be disassembled and inspected for wear or corrosion at a minimum of 2 year intervals, depending on service conditions. Complete rebuild kits are available from Metrex Valve.