

SELECTION CRITERIA

- Fresh water use
- Direct acting
- Patented 650 PSI rated actuator
- For R410a refrigerant applications
- Union NPT end connections
- 3-Way configuration
- 3/4" & 1" sizes
- 350 PSI water pressure standard
- Available water pressure to 500 PSI

CONSTRUCTION DETAILS

- Brass & stainless steel internals
- All O-Ring sealed (Buna-N)
- Cast iron body
- Brass union fittings with o-rings

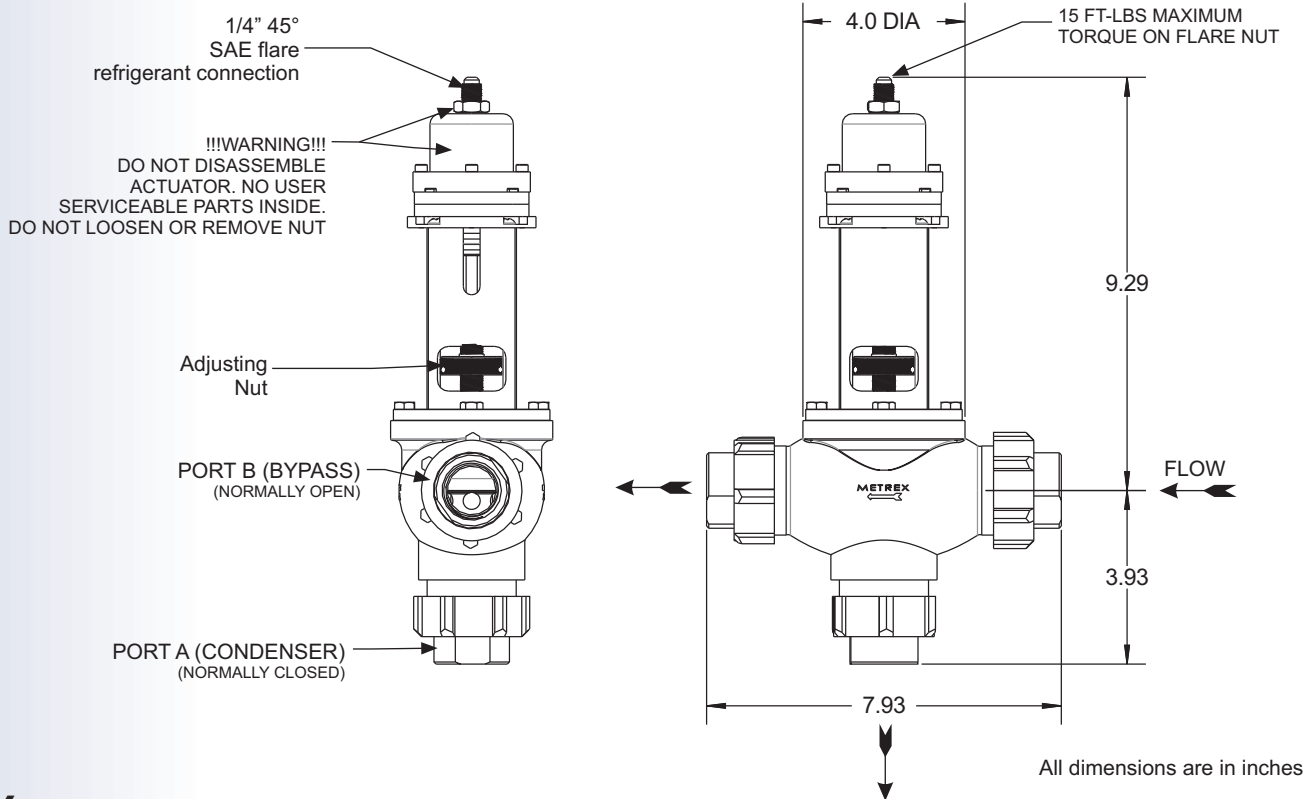

VALVE SIZING CHART & PRESSURE RATING

VALVE PART NUMBER	TRIM DESIGNATOR	PIPE SIZE	C _v	VALVE PART NUMBER	TRIM DESIGNATOR	PIPE SIZE	C _v
WCME65-4075_UE-3W-TA	TA	3/4"	8.5	WCME65-4075_UE-3W-TD	TD	3/4"	3.0
WCME65-4100_UE-3W-TA	TA	1"	8.5	WCME65-4100_UE-3W-TD	TD	1"	3.0
WCME65-4075_UE-3W-TB	TB	3/4"	1.5	WCME65-4075_UE-3W-TF	TF	3/4"	6.0
WCME65-4100_UE-3W-TB	TB	1"	1.5	WCME65-4100_UE-3W-TF	TF	1"	6.0

PRESSURE RATING			
PRESSURE RATING	STANDARD	H	EH
DESIGN PRESSURE	350 PSI	400 PSI	500 PSI
PROOF PRESSURE	525 PSI	600 PSI	750 PSI

ORDERING INFORMATION

- Use the valve sizing chart on the preceding page, tables, and charts below to determine the complete part number.

BASIC PART NO.: WCME65- 1 - UE-3W

VALVE SIZING CHART (4075, 4100)

SET POINT RANGE ("1" for R410a)

TABLE I ("H" OR "EH")

EXAMPLE: • "4100" = 1" pipe size
WCME65-41001H-UE-3W • "1" = 150-330 range
• "H" = 400 PSI water pressure

PRESSURE RANGE ADJUSTMENT

- The refrigerant pressure range which the valve begins to open can be adjusted per table II. An approximate increase of refrigerant pressure (span) per Table II is required to open the valve fully.

SET POINT RANGE	ADJUSTMENT	SPAN
1	150-330	55
2	TBD	TBD

All pressures are PSIG

FLOW DATA

VALVE FLOW DATA
(Either Port A or Port B fully open)

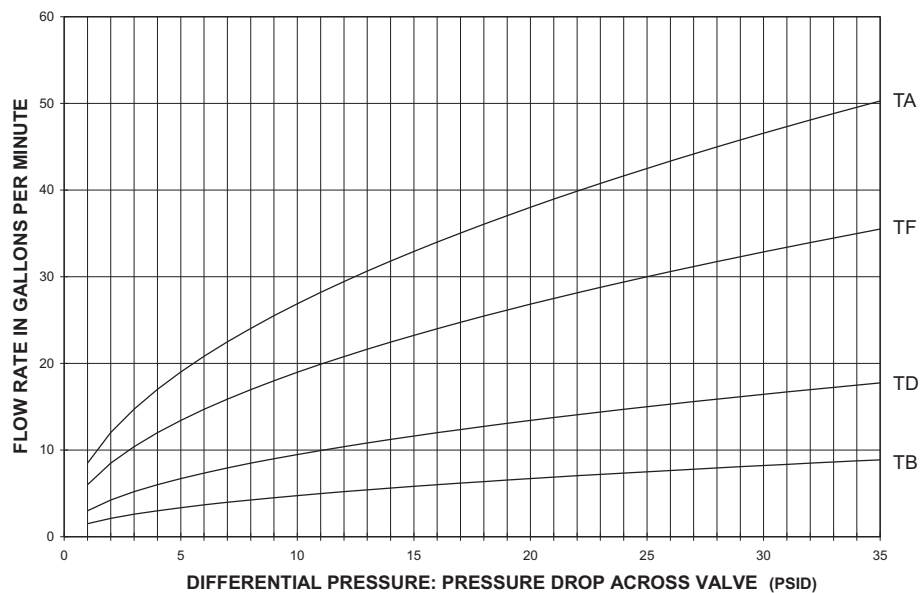

3-WAY HEAD PRESSURE REGULATOR TYPICAL APPLICATION

- Typically used to modulate the cooling water through a condenser in response to a pressure signal from the condenser. Refrigerant head pressure is maintained over a wide range of operating conditions for a maximum system operating efficiency.

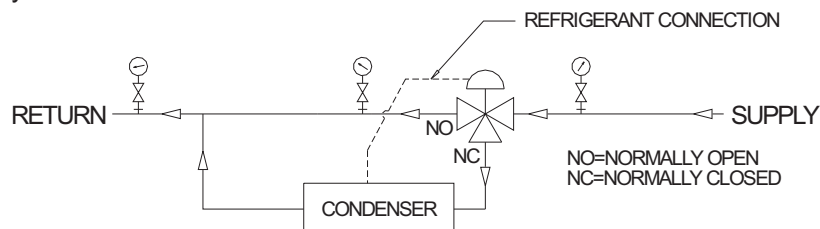

INSTALLATION INSTRUCTIONS

- 1) Valves can be mounted in any position without affecting performance. However, for ease of adjustment consider the accessibility of the adjusting nut.
- 2) Connect the incoming water line to the valve inlet. Direction of water flow is indicated by the arrow cast on the side of the valve body. Port A (normally closed) is typically piped to the condenser inlet. Port B should be piped to bypass the condenser.
- 3) Connect 1/4" male flare fitting on valve actuator to refrigerant head pressure connection on condenser. Use 1/4" copper refrigerant tubing, capillary tubing or other suitable tubing with 1/4" flare nut connection. Tubing not included with valve. Maximum tightening torque on flare nut is 15 in-lbs.
- 4) See Metrex datasheet 50M-366 for available capillary assemblies for connecting the valve.
- 5) Do not disassemble actuator. There are no user serviceable parts inside the actuator.

GENERAL DESCRIPTION

- The WCME65 series valves are high water pressure, direct acting, modulating water regulating valves. All water pressure boundaries are o-ring sealed for leak-proof, set & forget reliability. The WCME65 series is rated at 650 PSI refrigerant pressure for R410a service. Port A opens in direct response to refrigerant pressure. As Port A opens, Port B closes proportionally.

ADJUSTMENT

- All valve sizes are multi-range valves applicable to various refrigerants. The refrigerant pressure at which the valve begins to open can be adjusted as shown in Table II. An approximate increase in refrigerant pressure is required to fully open Port A is also listed in Table II.

To increase the actuating refrigerant head pressure, insert a pin or hex key into the adjustment nut and turn counter-clockwise. To lower actuating refrigerant head pressure, turn adjustment nut clockwise.