

## SELECTION CRITERIA

- Fresh water use
- Direct acting
- Actuation by pressure
- Open on pressure increase
- Optional reverse acting
- 150 PSI water pressure rating
- 225 PSI proof water pressure
- Screwed end connections NPT
- 2-way configuration
- 3/8", 1/2" & 3/4" sizes
- For high refrigerant pressure applications up to 460 PSIG, including R410a

## CONSTRUCTION DETAILS

- Brass & Stainless Steel internals
- Buna-N diaphragms & seals
- Brass body

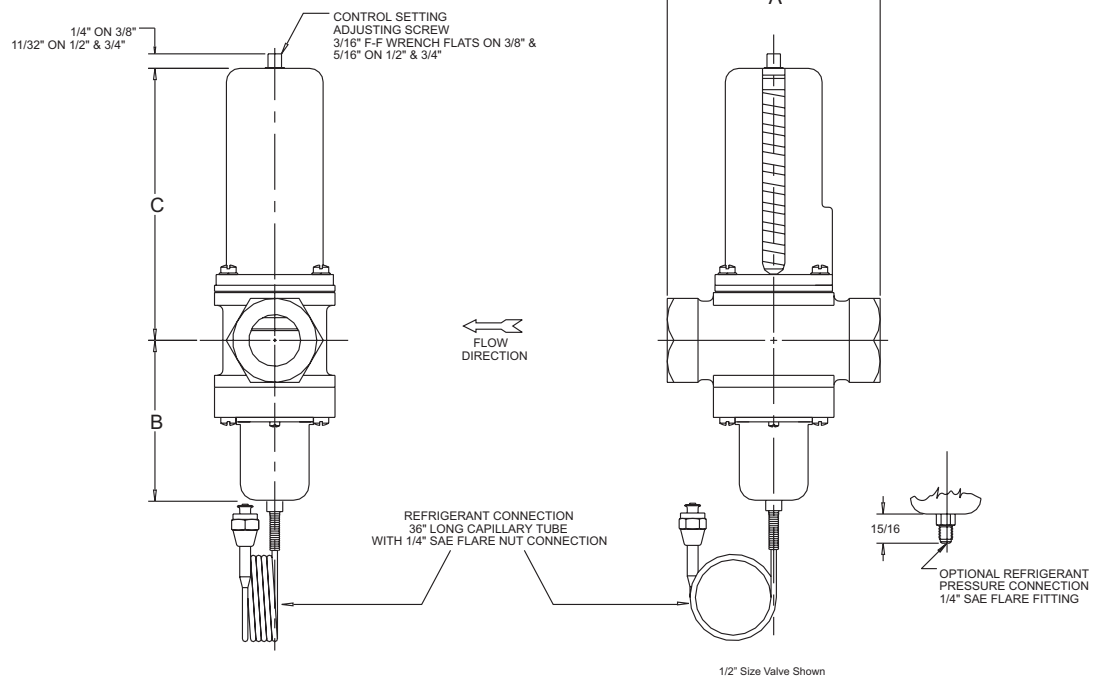

## VALVE SIZING CHART

VALVE PART NUMBER	PIPE SIZE	C <sub>v</sub>	DIMENSIONS		
			A	B	C
840P-37SE	3/8"	2.3	2-3/4"	2-1/4"	3-7/16"
840P-50SE	1/2"	3	3-1/8"	2-9/16"	3-21/32"
840P-75SE	3/4"	5	3-1/2"	2-11/16"	3-13/16"

## ORDERING INFORMATION

- Use the valve sizing chart on the preceding page tables and charts below to determine the complete part number.

**BASIC PART NO.: 840P - -SE**

BELLOWS OPTIONS  
VALVE SIZING CHART

## PRESSURE RANGE ADJUSTMENT

- The refrigerant pressure at which the valve begins to open can be adjusted from 150 to 400 PSI. A pressure increase of approximately 55 PSI is required to open the valve fully.

## BELLOWS OPTIONS

- The optional 1/4" male SAE flare fitting for refrigerant pressure connection is designated by an "F" after the P. The 1/4" SAE Flare Fitting replaces the 36" long capillary tube with 1/4" SAE flare nut connection.
- The optional reverse acting configuration (closes on a pressure increase) is designated by an "R" after the P.

Example: 840PE-100-SE.

Example: 840PR-50-SE.

## VALVE FLOW DATA

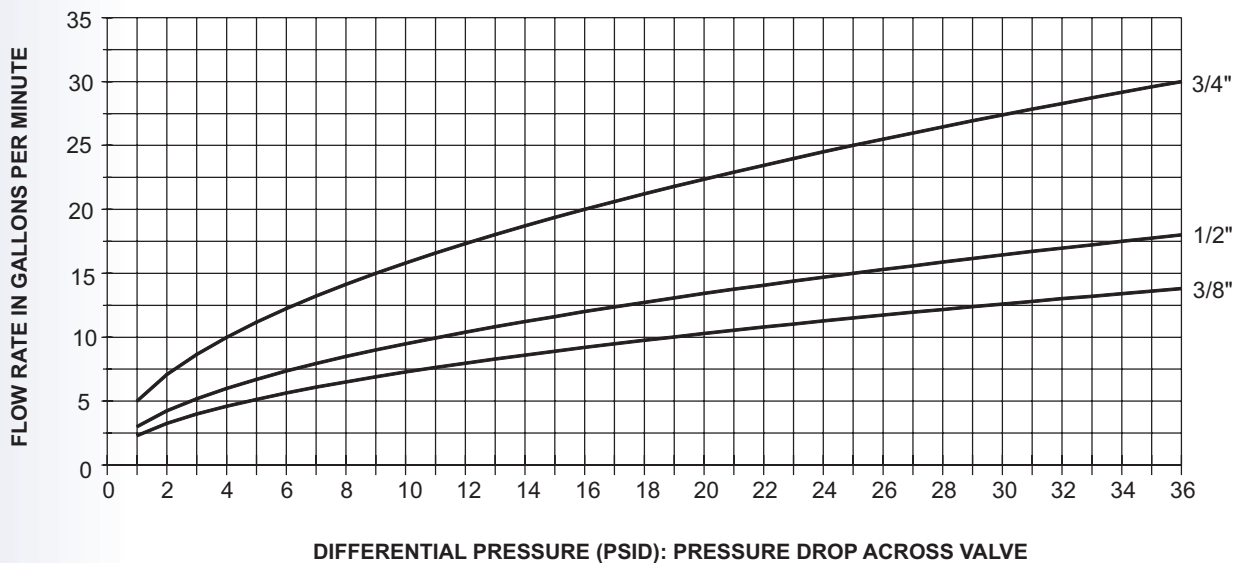

## 2-WAY HEAD PRESSURE REGULATOR TYPICAL APPLICATION

PAGE 3 OF 3

- Typically used to modulate the cooling water through a condenser in response to a pressure signal from the condenser. Refrigerant head pressure is maintained over a wide range of operating conditions for a maximum system operating efficiency.

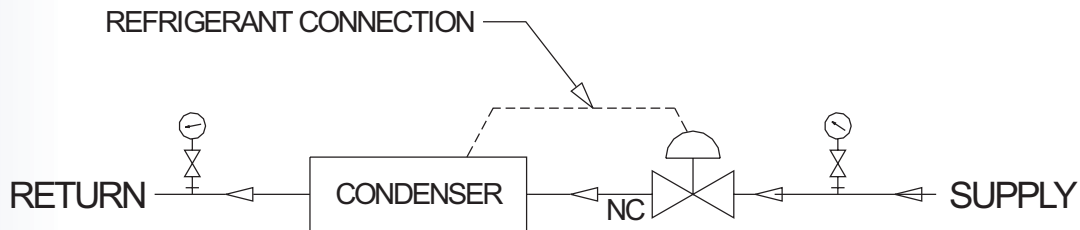

## INSTALLATION INSTRUCTIONS

- Valves can be mounted in any position without affecting performance. However, for ease of adjustment, consider the accessibility of the adjusting screw.
- Connect the incoming water line to the valve inlet. Direction of water flow (see drawing) is indicated by the arrow cast on the side of the valve body.
- Connect capillary tube (or 1/4" flare nut) to refrigerant head pressure connection on condenser.

## GENERAL DESCRIPTION

- The 840 series valves are direct acting, modulating water regulating valves utilizing a diaphragm construction to give a smooth, well balanced action. The pressure-balanced design and low frictional co-efficient of the diaphragm assure fast response to changes in refrigerant pressure and protection against both gradual and sudden water pressure changes. All sliding parts and adjustment springs are isolated from the water flow by the leak proof diaphragms.

## ADJUSTMENT

- All valves in 3/8" through 3/4" sizes are primarily for R-410a service. The refrigerant pressure at which the valve begins to open can be adjusted from 150 to 400 PSI. An approximate 55 PSI increase of pressure is required to open the valve fully.

To adjust condensing head pressure, use a wrench and turn adjusting screw on top of the spring housing. Turn to the right (counter clockwise) to raise the opening point and the left (clockwise) to lower.

## MANUAL OVERRIDE

- All valves may be manually flushed by inserting a screwdriver in openings at opposite sides of the spring housing and lifting the lower spring plate to open the valve. The valve adjustment is not affected by manual flushing.

